

Recommendations for the Installation of Junctions in the Vertical Position

PD 54 A

28/05/02

All types of junction manufactured by Stanton Bonna are designed to support axial forces resulting from the normal jointing activities of the connecting branch pipe or adaptor.

Neither the branch, sealing element (in the case of uni-junctions) nor the pipe itself are designed to support axial loading by any other means.

The arrangement of the connecting pipework should be designed so as to ensure that there is no possibility of axial loading at junctions.

Stanton Bonna recommend that connections to junctions should not be made with vertical or near vertical drops of the connecting pipe. Where circumstances make this unavoidable the manufacturer of the connecting pipework should be consulted for guidance on the prevention of axial loading.

Junctions are not designed to support loads from the surrounding ground and should be encased in a suitably designed in-situ concrete surround.

This advice applies to cast and fabricated junctions and uni-junction pipes.

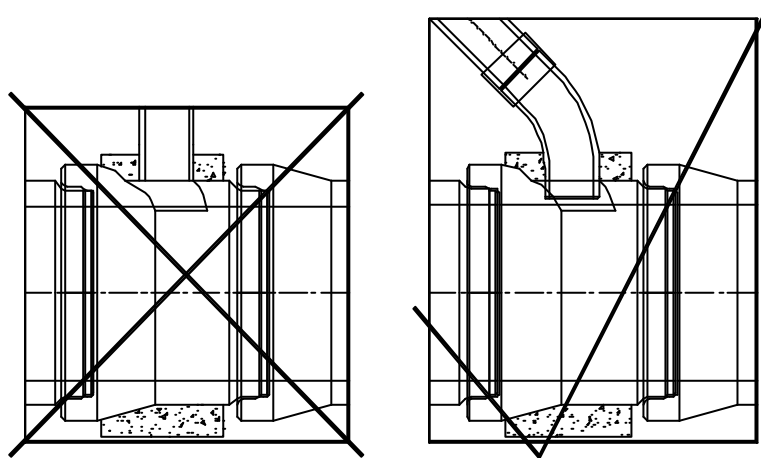

Right to Change: The specifications given in this document are believed to be correct but are not guaranteed. Stanton Bonna reserve the right to alter any specifications given in accordance with its policy of continuous product development. All rights reserved.

STANTON BONNA CONCRETE LTD, LITTLEWELL LANE, STANTON-BY-DALE, ILKESTON, DERBYS. DE7 4QW
TEL: (0115) 944 1448 FAX: (0115) 944 1466 E-MAIL: sales@stanton-bonna.co.uk