

Instructions for the Use of DN 1200 Jacking Pipe Lifting Eyebolts

PD 52 rev B 14/10/04

INTRODUCTION

Stanton Bonna jacking pipes are supplied with a single hole cast through the pipe wall to facilitate lifting of the pipe. To provide a safe and efficient means of lifting DN 1200 pipe a suitably designed lifting eye is supplied, as shown below.

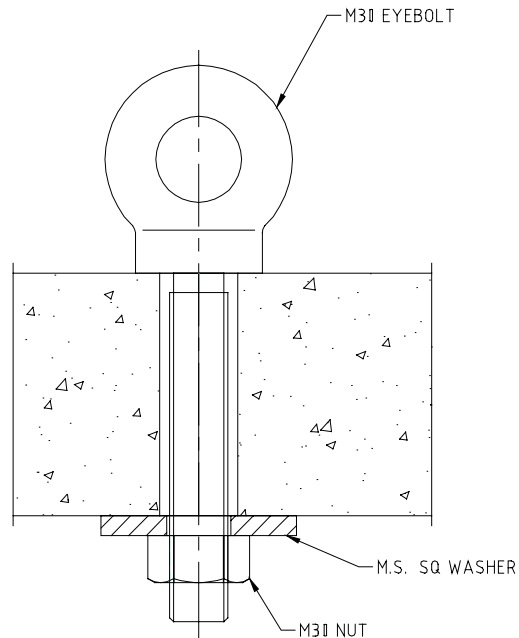

All lifting and handling operations should be carried out using safe working practices in accordance with the requirements of statutory health and safety regulations.

FITTING THE EYE

The lifting eye comprises of three components: a lifting eye, nut and steel plate washer. The lifting eye should be passed through the lifting hole from the outside of the pipe. From the inside of the pipe, fit the steel washer and then the nut.

Tighten the nut until the underside of the head of the lifting eye is in contact with the pipe wall. The nut should be tight enough to ensure that contact between the pipe wall and the head of the lifting eye is maintained.

LIFTING OF PIPES

Pipes should be lifted using a single lifting chain to ensure vertical loading of lifting eye. Under no circumstances should the lifting system be used to lift more than one pipe at a time or to aid the jointing of pipes.

After lifting of the pipe the lifting eye should be removed and the lifting hole filled. DN 1500 jacking pipes can be lifted using a M36 5.3 Ton WL.L long shank eye nut (available upon request).

MAINTENANCE

Lifting equipment is tested in accordance with the (Lifting Operations and Lifting Equipment Regulations 1997 (Loler). It should be regularly inspected for signs of wear and tear by a competent person.

Right to Change: The specifications given in this document are believed to be correct but are not guaranteed. Stanton Bonna reserve the right to alter any specifications given in accordance with its policy of continuous product development. All rights reserved.

STANTON BONNA CONCRETE LTD, LITTLEWELL LANE, STANTON-BY-DALE, ILKESTON, DERBYS. DE7 4QW
TEL: (0115) 944 1448 FAX: (0115) 944 1466 E-MAIL: sales@stanton-bonna.co.uk