

Installation of Elliptical Pipes

PD 29 rev E

20/09/05

1. Scope

This document gives basic guidance on the installation of Stanton Bonna Elliptical pipes under normal conditions. When circumstances vary, supplementary instructions may be required and should be provided by the overall scheme designer.

Users should note that this document is not a comprehensive guide to pipeline installation and it is expected that the work is executed under the control of suitably qualified and experienced personnel.

For further information on pipeline installation, reference should be made to 'Laying precast concrete pipelines in trench' published by the Concrete Pipeline Systems Association (Tel: 0116 253 6161).

2. Receipt of Goods

On receipt the delivery should be checked to ensure that:

- The delivery note corresponds to the goods in the consignment.
- Pipes are free from damage, especially at the ends.
- Pipes are marked with the date of manufacture, the proof load and the pipe orientation. Pipes designed for vertical installation must never be installed in the horizontal position and vice versa.
- Jointing lubricant has been supplied.

3. Handling and Storage

3.1 Handling

Unloading and handling on site must be undertaken carefully in order to avoid damage to products.

Particular care should be taken to avoid impact damage to the ends of the unit.

Pipes should be lifted either by the use of broad canvas slings passed around the outside or with the use of the lifting anchors. These cast in anchors are provided in order that the units can be lifted in both horizontal and vertical orientations as necessary.

For instructions on the use of the lifting system reference should be made to the Stanton Bonna Product Guide pages 1.3.4 and 1.3.5.

Note:

- When lifting Elliptical pipes in the horizontal orientation using three anchors in the top surface, chain A should be attached to the single anchor at the socket end of the pipe. Shortening of leg C using the shortening clutch provided is necessary.
- Chains supplied for Elliptical pipes are for lifting only and should not be used for jointing.

Elliptical pipes may be delivered in a horizontal orientation. Turning of units to be laid in the vertical position should be undertaken safely and in a manner that avoids damage to the unit. For proposed method of turning see PD 61 available on request

When using the lifting anchors, lifting and lowering must be undertaken slowly and steadily, avoiding snatch loading. Transportation by crane must be undertaken slowly over level ground and only for short distances.

3.2 Pipe Dimensions

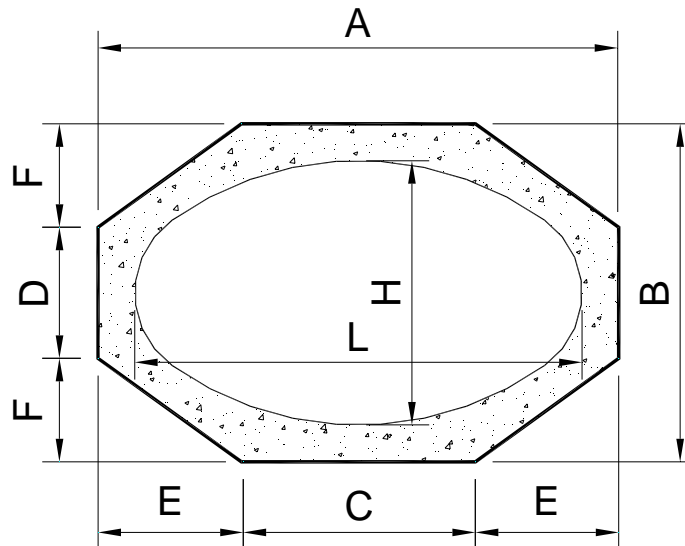

Fig 1

L x H (mm)	A x B (mm)	C (mm)	D (mm)	Effective Length (m)	Approx Mass (kg)
1000 x 650	1250 x 900	520	370	2.40	2600
1150 x 750	1400 x 1000	600	430	2.40	3000
1650 x 1000	1930 x 1280	850	500	2.40	4600
1950 x 1150	2270 x 1470	1020	570	2.40	6300
2350 x 1350	2710 x 1710	1230	670	2.40	8600
2650 x 1500	3050 x 1900	1450	740	2.40	10800

Table 1: Pipe Dimensions

3.3 Storage

Units should be stored on firm level supports which are clear of the ends. They should remain free from soil and contamination from substances, such as mineral oils and grease, that may damage the pipes or gasket.

Units must not be stacked on site.

4. Excavation and Preparation

4.1 Trench Width

In the case of installation in trench the trench shall be excavated to the width shown on the drawings.

Trench width should not exceed the maximum width used in the design and should not be narrower than that required to place and compact bedding and backfill materials.

Elliptical Pipe	Max Trench Width (m)
1000 x 650 Vert	1.70
1150 x 750 Vert	1.80
1650 x 1000 Vert	2.10
1950 x 1150 Vert	2.25
2350 x 1350 Vert	2.50
2650 x 1500 Vert	2.70
1000 x 650 Horiz	1.85
1150 x 750 Horiz	2.00
1650 x 1000 Horiz	2.75
1950 x 1150 Horiz	3.05
2350 x 1350 Horiz	3.50
2650 x 1500 Horiz	3.85

Table 2: Recommended Maximum Trench Widths

4.2 Bedding Types

The following bedding types are recommended for use with Elliptical pipes in both the vertical and horizontal orientation. The bedding details should be specified on the contract drawings.

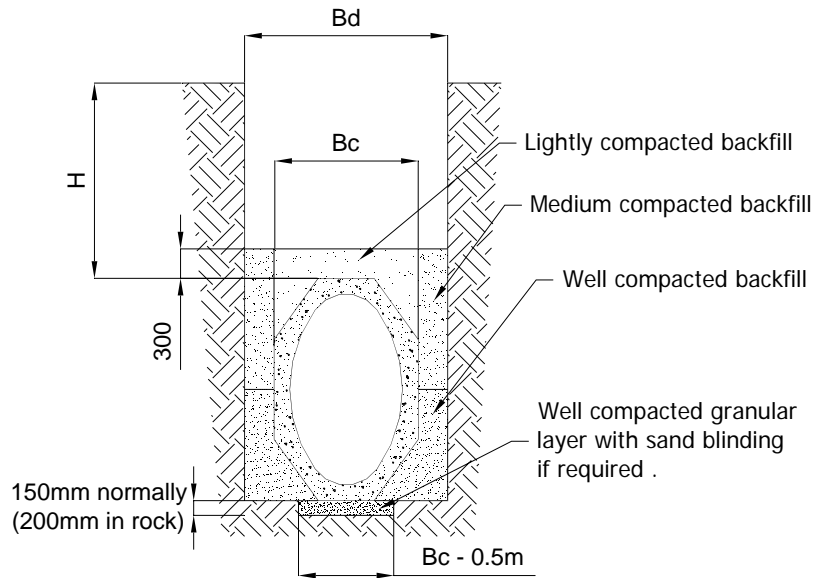

Fig 2: Standard Bedding, $f_m = 1.5$

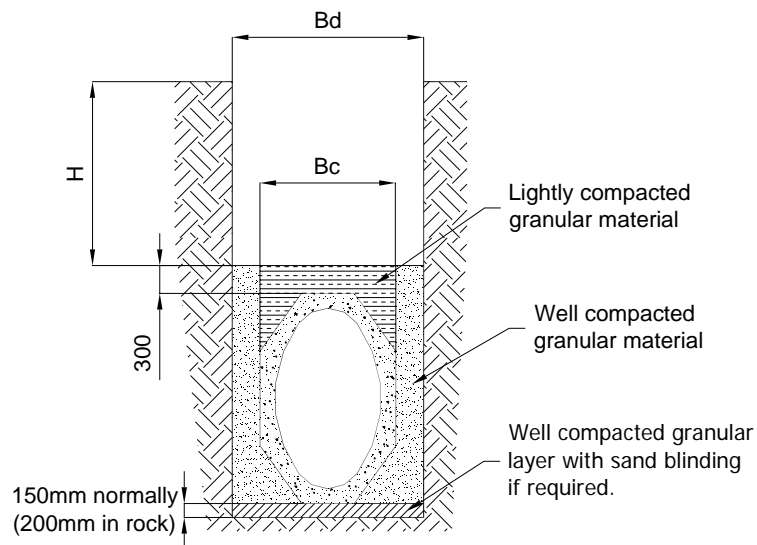

Fig 3: Full Bed and Surround, $f_m = 1.9$

4.3 Formation

It is essential to ensure uniform support of the pipeline. Hard or soft spots in the formation should be removed and replaced with bedding or selected backfill material.

Ground water should be kept below the bottom of the trench.

In conditions of unstable ground special precautions may be necessary.

4.4 Bedding Materials

Angular bedding material such as crushed gravel or rock is recommended as bedding for Elliptical pipes.

The material should be of similar particle size to the material in which the trench is excavated in order to avoid migration of fines to or from the bedding. Alternatively a geotextile membrane can be used to separate the bedding from the surrounding soil.

Where gradients are steep or where there is a possibility of groundwater movement that could risk disturbing the bedding, special precautions should be considered.

Maximum particle size should not exceed 40 mm.

Under no circumstances should blocks or bricks be placed beneath pipes and any pegs used for setting out or levelling must be removed.

5. Jointing

5.1 Preparation

The granular bedding material in the bottom of the trench should be laid to the specified thickness and levelled. Alternatively a 75 mm unreinforced lean mix concrete can be laid on a formation that has been prepared to a uniform firmness.

In order to prevent collection and trapping of granular bedding material in the bottom of the joint, a 25 mm deep, 100 mm wide niche should be dug in front of the joint of the previously laid pipe. The niche should extend either side of the base of the unit.

Before lowering the pipe into position the spigot and socket of the joint concerned should be cleaned and inspected to ensure they are free from damage.

The spigot surface and the gasket shall be coated with joint lubricant supplied by Stanton Bonna. Do not use oils, grease etc as they can damage the gasket.

Elliptical Pipe	Lubricant Required (kg/joint)
1000 x 650	0.5
1150 x 750	0.5
1650 x 1000	0.8
1950 x 1150	0.9
2350 x 1350	1.2
2650 x 1500	1.4

Table 3: Lubricant Quantities

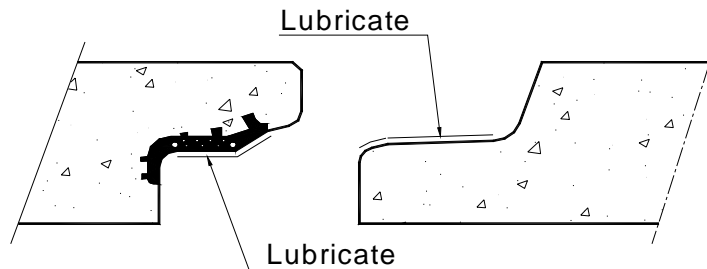

Fig 4

5.2 Jointing

The unit should be lowered into the trench and the spigot entered into the socket of the previously laid pipe. It should be allowed to rest on the bedding with support from the crane.

The alignment of the pipe should be adjusted until the spigot and socket of the joint are square and concentric.

Pipes may be adjusted by pushing down on the crown with mechanical equipment. When carrying out this operation timber packings shall be used to avoid damage to the pipe.

The weight of the pipe should not be supported on the gasket.

When the joint is correctly aligned it should be pulled home by means of a Tirfor, a hydraulic cylinder or pushed home by using the excavator arm as shown below.

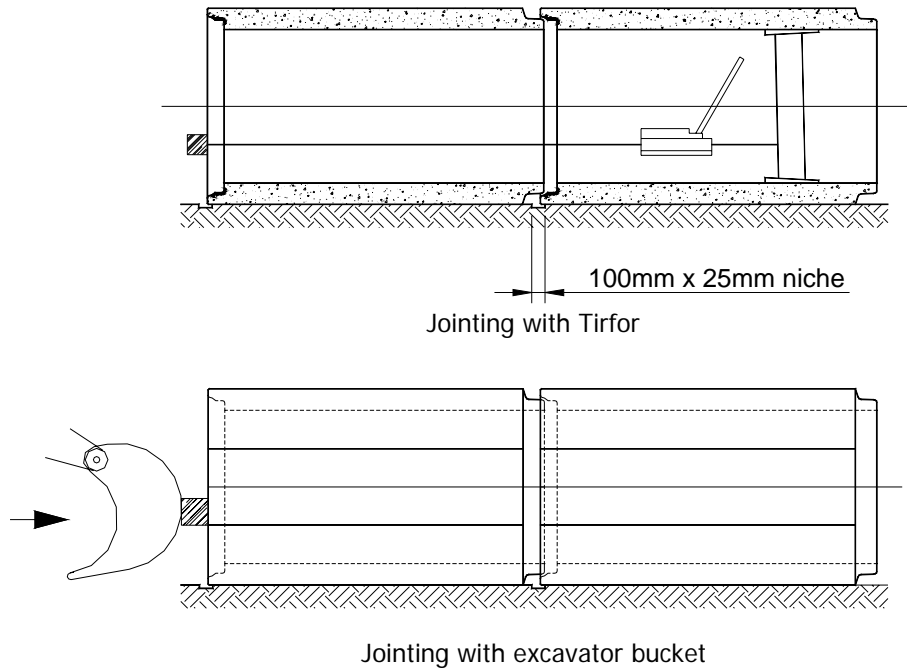

Fig 5

During jointing the joint should be inspected to ensure the spigot is moving smoothly into the socket and that no damage to the joint or displacement of the gasket occurs.

Care should be taken to ensure that the pipes remain square during the operation. If the joint starts to close on one side only, packings should be placed at springing level to stop further closure until the joint is square.

If jointing forces increase suddenly it is likely that the joint is misaligned and locked tight. The pipe should be disjointed and realigned before continuing.

After completion of jointing line and level should be checked. Joint gaps should be not less than 5 mm nor more than 25 mm. The verticality of the axis of the socket should be checked using a plumb bob and the marks on the concrete face.

5.3 Anchor Recesses

Prior to backfilling anchor recesses should be made good flush with the outer surface with epoxy or polyester resin or a 1:3 cement sand mortar proportioned by mass.

Note that it may be more convenient to make good anchors that are not required for lifting into the installed position, before jointing.

6. Backfilling

6.1 General

Backfilling should proceed as soon as possible after laying.

Material should be placed in layers and compacted, where necessary, evenly on both sides of the pipe. It should be carefully placed in position and not dropped or bulldozed into the trench.

Trench supports should be removed as backfilling proceeds, particularly in the case of 'Full Bed and Surround' bedding.

6.2 Backfill Material

Material for backfill should be similar in character to the surrounding soil. It should be readily compactable, free from large lumps, roots, rubbish and building rubble.

Compaction requirements for backfill material are governed by activities that occur over the pipeline. However, it is important to ensure that no hard spots are created over the pipe which can cause point loading.

6.3 Crossing of Pipeline

There is a risk that construction plant will apply loads on the pipeline which are in excess of that for which it may have been designed, especially as such loading may occur before the ground has been brought up to finished level.

Before any crossing of the pipeline is made the designer should be consulted.

7. Acceptance Tests

The pipeline should be visually inspected to check for:

- Joint gaps within allowable limits.
- Obstructions and debris.
- Structural soundness.
- Properly sealed joints, eg ingress of water or misplaced gaskets.
- Line and level.

NOTE

(i) This document is subject to periodic revision. Please check with Stanton Bonna that you have the latest version.

(ii) This document is only applicable to Stanton Bonna Elliptical pipes. It must not be used in connection with any other type of product manufactured by Stanton Bonna or others.

Right to Change: The specifications given in this document are believed to be correct but are not guaranteed. Stanton Bonna reserve the right to alter any specifications given in accordance with its policy of continuous product development. All rights reserved.

STANTON BONNA CONCRETE LTD, LITTLEWELL LANE, STANTON-BY-DALE, ILKESTON, DERBYS. DE7 4QW
TEL: (0115) 944 1448 FAX: (0115) 944 1466 E-MAIL: sales@stanton-bonna.co.uk