

T 0115 944 1448
 F 0115 944 1466
 E info@stanton-bonna.co.uk
 W www.stanton-bonna.co.uk

Perforated Drainage Troughs

Precast concrete perforated drainage troughs are a modular system for trackside drainage applications.

■ Cover AV

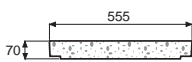

■ Trough M40-15

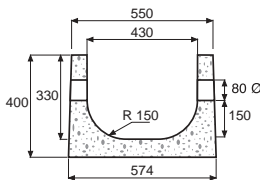

■ Trough M50-25

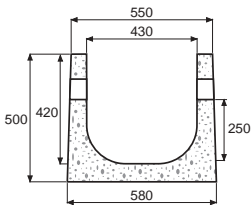

■ Riser H37

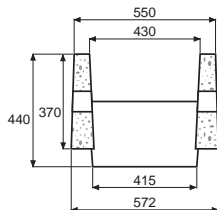

■ Riser H58

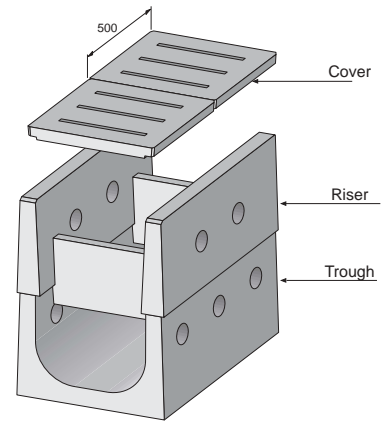
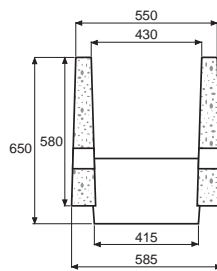

■ Trough M60-15

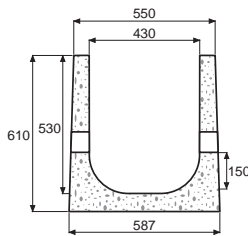

■ Trough M70-25

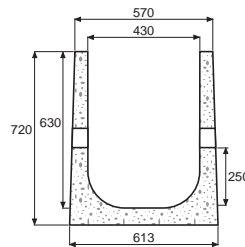

■ Trough M80-15

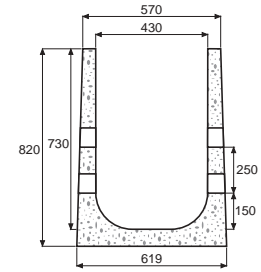

Perforated Drainage Troughs Data			
Type	Component	Length m	Weight kg
Cover AV	Cover	0.50	42
Trough M40-15	Trough	1.00	228
Trough M50-25	Trough	1.00	274
Trough M60-15	Trough	1.00	319
Trough M70-25	Trough	1.00	415
Trough M80-15	Trough	1.00	466
Riser H 37	Riser	1.00	176
Riser H 58	Riser	1.00	277
System M32-12	Cover	1.00	31
	Riser	1.00	81
	Trough	1.00	100

■ System M32-12

